

"Studio"

Heat Recovery Unit
with Low Energy DC Motor

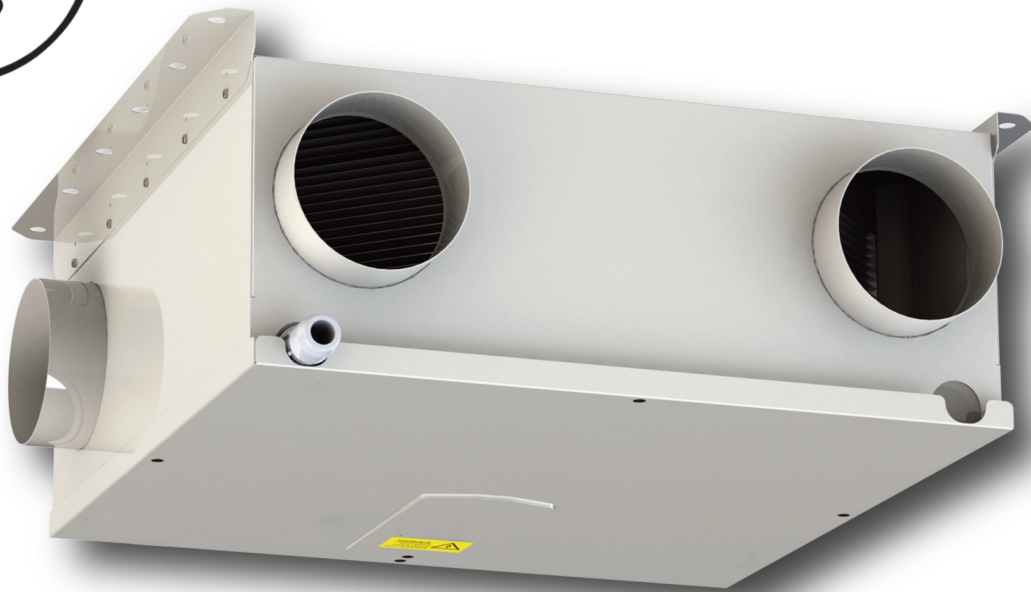

Installation, Operating
and Maintenance Instructions



"STUDIO" - HEAT RECOVERY UNIT INSTALLATION AND OPERATING INSTRUCTIONS

SAFETY NOTICE

It is important to read this Instruction Manual carefully before installing or using the product. Following these instructions will ensure that your ventilation system is installed, commissioned and used properly and continues to operate effectively. Vectaire will not be held responsible and will not accept liability for any damage caused to persons or property through failure to follow the guidance provided in this manual. It should always be available with the product for easy reference.

Your unit **SHOULD NOT** be switched off (except during maintenance). It is designed to run continuously. If it is switched off indoor pollutant and moisture levels may increase.

Studio: 125mm spigot, for continuous ventilation
Max airflow 63 l/s

GENERAL INFORMATION

The Vectaire Studio heat recovery system provides mechanical ventilation to bedrooms and bathrooms. It extracts stale, contaminated air from bathrooms, replaces it with fresh air to the bedroom and vents the stale air to the outside.

Heat is reclaimed from the extracted air and used, via a heat exchanger, to warm the incoming fresh air. The extract and intake airstreams are completely separate to avoid cross-contamination.

The system operates continuously and is designed not to be switched off, except for maintenance purposes.

During normal operation, the unit produces a low-volume airflow, creating a comfortable, healthy environment, with minimum energy consumption.

If additional ventilation is required, (e.g. when a shower is in use), a boost facility is included which increases the airflow rate. The boost can be operated automatically or manually.

Installation of the unit is usually above a ceiling or in a loft space and is connected to air vents via hidden ductwork.

Each unit is commissioned individually allowing its performance to be matched to the size of area to be ventilated.

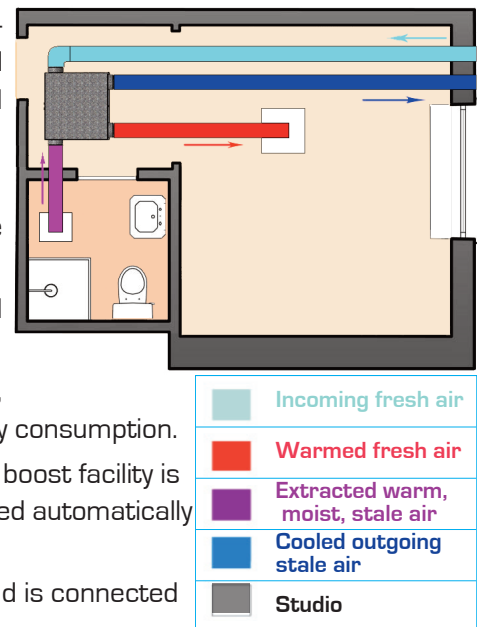

STANDARD FEATURES

1. Variable adjustment of low (trickle) and boost speeds for optimum setting at installation.
2. Adjustable overrun timer on boost setting - factory set to zero.
3. Adjustable delay-on timer, factory set to 2 minutes
4. Adjustable night-time boost inhibitor set to operate from 10.00 p.m to 6.00 a.m
5. Multiple choice of external devices for automatic or manual boost switching (e.g. light switch, remote switch/pull cord, PIRFF passive infra-red*, DRH240 humidistat*, THM thermostat*.)

* **Note** : Contact Vectaire for supply of these items.

OPTIONAL ADDITIONAL FEATURE

BMS connections for remote motor shut-off.

DIMENSIONS - mm

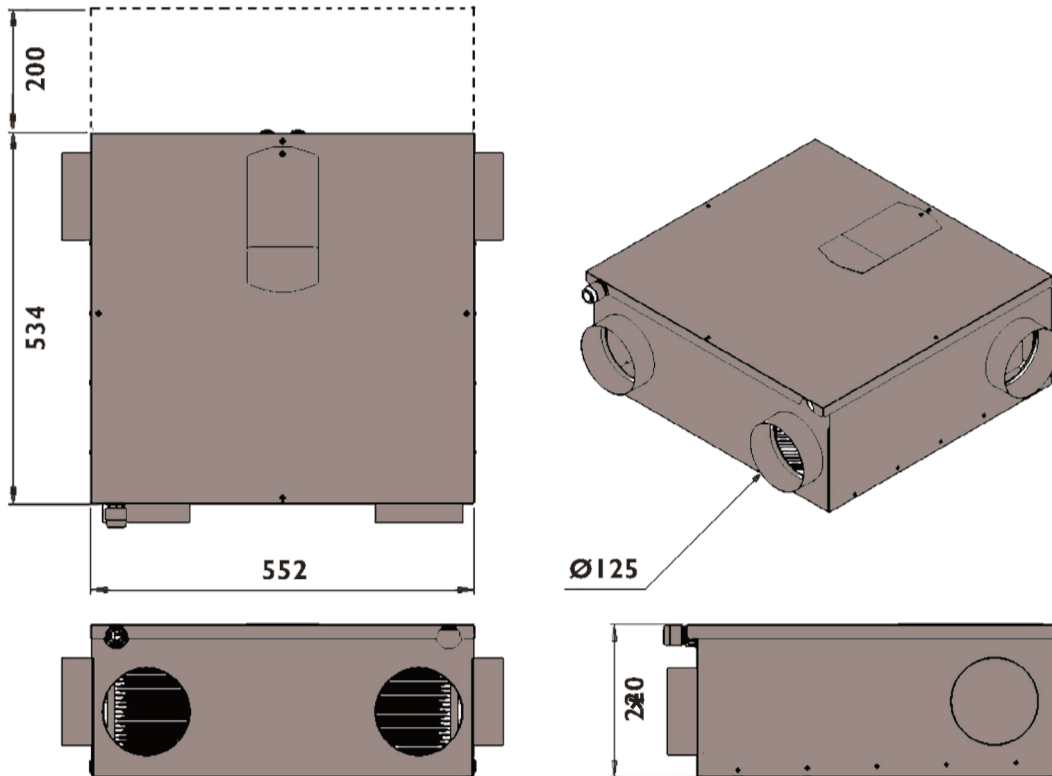

N.B a clearance of at least 200 mm should be allowed at the rear of the unit in order to replace filters.

* 236mm with mounting bracket on drain side

GENERAL SAFETY

PLEASE READ THESE INSTRUCTIONS FULLY, BEFORE ATTEMPTING ANY INSTALLATION

1. This product must not be used for any purpose other than that for which it was designed and shown in this leaflet.
2. All packaging should be removed and the unit checked for damage. If any damage is found, contact your supplier.
3. This product will normally be fitted into a loft or ceiling void.

In order to comply with Construction (Design & Management) Regulations, sufficient access for safe maintenance (recommended on an annual basis), or removal following installation, MUST be provided for this product. See dimensions above.

4. The unit must NOT be installed:
 - where there is excessive oil or grease
 - where there are hazardous gases, liquids or vapours that are flammable or corrosive
 - in ambient temperatures above 50°C or lower than 5°C
 - in humidity levels above 90% or in a wet environment
5. **If any room from which air is extracted contains a fuel burning appliance, such as a central heating boiler, then its flue must be of the sealed or balanced flue type, or allowance must be made for an adequate supply of air into the room.**
6. The mains supply voltage and power rating must comply with the details on the product rating label.

INSTALLATION

Installation must be carried out by a suitably qualified person and must comply with all current building regulations and electrical installation regulations.

Mounting the unit

Before choosing the position for mounting, it is important to take into consideration the ductwork routes and condensate drain route. The four spigots on the unit are marked for the four unique connections. The unit can be supplied left or right-handed in order to match the required duct routes more easily. (Factory option only.)

Studio - option 1 (right hand drain)

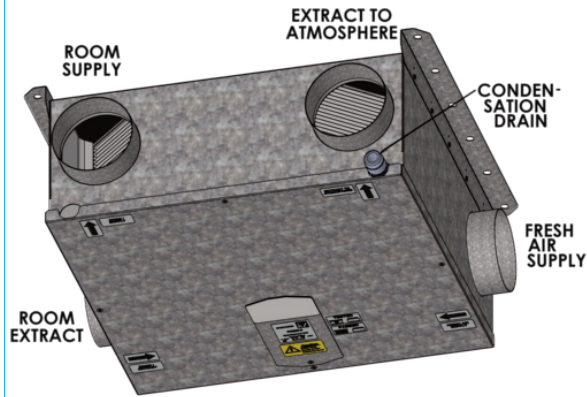

Studio - option 2 (left hand drain)

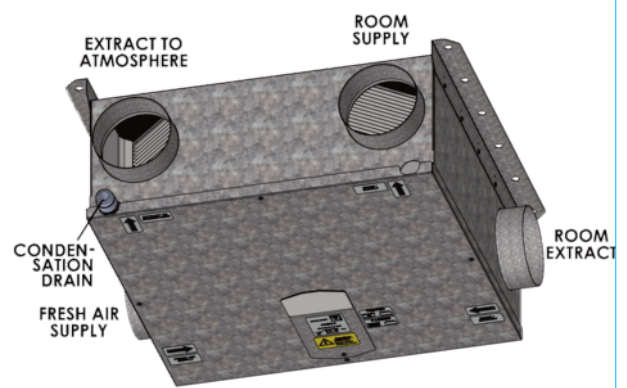
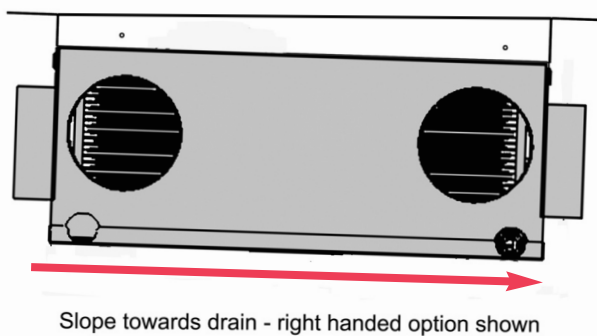

Diagram showing slope towards drain



It is also essential that adequate access to the product is provided for maintenance or removal after installation. The entire access panel needs to be removed for maintenance.

The unit is intended to be suspended from a ceiling or similar fixture. Two identical fixing brackets are supplied with each unit. It is important that the unit is attached to these brackets so that there is a slope down towards the condensation drain connector of the product. When correctly fitted, the brackets will provide a drop of approximately 15mm at the lower end.

Duct and Duct Connections [refer to design drawing]

1. 4 x 125mm nominal diameter spigots are provided for the connection of ducting. These are clearly marked for correct connection of the supply and exhaust ducts.
2. Where ducting is installed in an unheated space, all of the ducts should be insulated. Where ducting is installed in a heated space, only the cold ducts should be insulated. i.e. the supply duct from outside and the extract duct from the unit to the outside.
3. The duct layout must be designed to suit the requirements of the ventilation/heat recovery system and building layout. If the ducting passes through a fire wall/barrier, suitable fire dampers must be installed.
4. Where rigid duct is used (preferable), it should be installed using the least number of fittings to minimise air flow resistance. Where possible, final connection to the grilles and unit should be made with a flexible connection.
5. Where flexible ducts are used, ensure that:
 - duct runs are kept as short as possible
 - the duct is stretched so that it is smooth and straight
 - where bends are necessary, they have large radii (ie avoid sharp bends)
 - the duct is not crushed if in a restricted area

Note: Whenever the unit is installed in close proximity to a bedroom or other habitable space, we recommend that sound attenuation is provided within the duct runs between the rooms and the unit. A length of 1 metre of flexible acoustic ducting will be sufficient in most circumstances, but reference should be made to the sound data provided for this product



Condensate Drainage

The unit may sometimes produce condensation which must be drained away. A 15mm dia pipe connection is provided on this unit.

1. A 15mm rigid PVC push-fit pipe must be used for connection to the unit.
2. **IMPORTANT : A solvent weld must NOT be used on this joint as the joint has to be disconnected in order to remove the heat exchanger for cleaning.**
3. The condensate drain pipe must be suitably trapped order to prevent air egress from the unit.
4. The drainage pipe must have a continuous fall from the unit to the drainage collection point.
5. If any part of the condensate drain is in an unheated space it **MUST** be insulated with the equivalent of at least 25mm of insulating material with a thermal conductivity of 0.04 W/mK.

Note:

1. In order to prevent any possible condensate overspill from the unit, excess water in the condensate tray will be detected and the motors will switch off to prevent further condensation from forming. If this happens, a warning light on the unit will flash.
2. The cause of this will usually be inadequate drainage. The drain must be inspected and cleared of any blockage and the correct rate of fall from the unit must be ensured.
3. Once the drainage problem has been resolved, the unit will automatically restart after 5 minutes.

Electrical Connection

WARNING: these appliances must be earthed and all wiring must conform to current IEE Regulations and all applicable standards and Building Regulations.

- The unit is suitable for 230V, 50Hz Single phase supply.
- The unit is supplied with:
 - A mains rated 4 core flexible cord (black, brown, grey, green/yellow)
 - An optional factory-fitted 2 cord volt-free flexible cord for purge switching
- Cables for any other external device can be **provided and labelled on request**
- A triple pole isolation switch with contact separation of at least 3mm must be used to connect the appliance to the fixed wiring when using the Switched Live.
- Boost and other external controls should be clearly identified and conveniently located.
- The boost facility can be activated by a switched live connection (in addition to the permanent supply live).

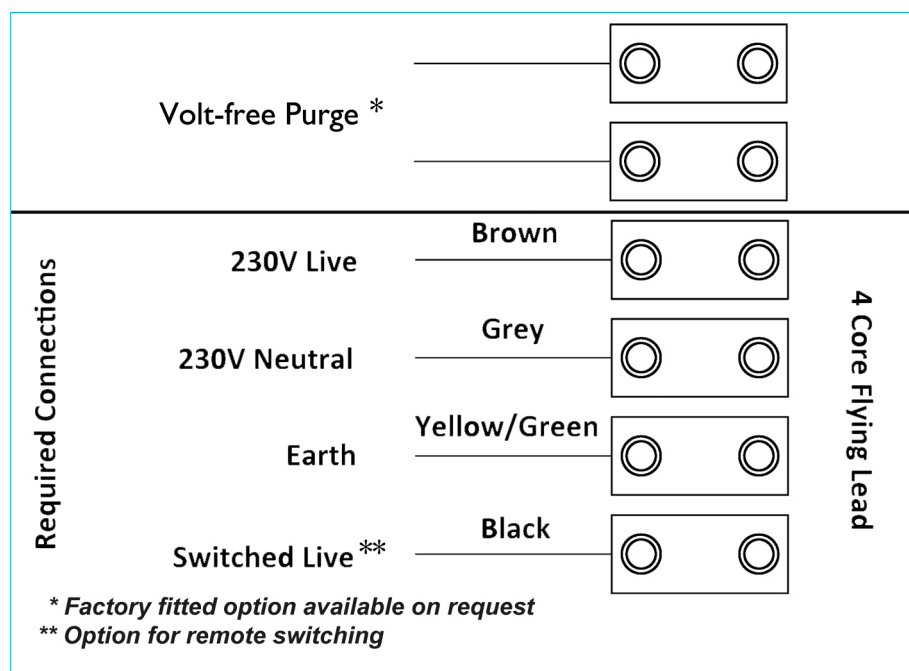



COMMISSIONING

Pre-programmed Settings

The fans are supplied pre-programmed at the required motor speed settings and no adjustment should be necessary for standard rooms.

1. The commissioning must only be carried out by a suitably qualified person.
2. Prior to starting the commissioning procedure, ensure that the ductwork connections and airflow directions match one of the options 1 or 2, shown on page 4. Check that the drain connection is on the correct side.
3. Before making any adjustments, ensure that the air valves or grilles are fully open.
4. **Please see separate "LCD Control Panel Commissioning Instructions" for details on commissioning and user operations..**

WARNING : With the control board panel removed, 230 volt live connections are accessible.

Cleaning and Maintenance

WARNING: The unit uses a 230V supply and contains rotating mechanical parts.

Before carrying out any maintenance or cleaning the mains electrical supply MUST be disconnected, including any switched live connections.

Filter Cleaning/Replacement (should be checked every three months or more often if the environment warrants it)

1. Remove the filter access strips from the rear panel.
2. Slide out the filters by pulling the tabs.
3. Clean the filters carefully using a vacuum cleaner. Replace the filters in the slots and refit the covers.
4. Filters should be replaced annually or after a maximum of three cleaning cycles.

Heat Exchanger Access and Cleaning (should be cleaned annually)

1. Turn off the unit and isolate it from the mains power supply, including any switched live connections
2. Disconnect the condensate pipe from the condensate connector.
3. Remove the four screws retaining the access panel and completely remove the panel.
4. Remove the drain tray downwards and keep it level as there may be water within the tray.
5. The heat exchanger has a plastic strap around it. Pull the strap gently downwards, keeping the heat exchanger as horizontal as possible as there may still be water inside it.
Once removed, ensure there is no water in the heat exchanger and that it is dry.
6. Using a vacuum cleaner with a soft brush attachment, carefully remove any dust from the faces of the heat exchanger.
7. Check that the drain connector is clear of any deposit or blockage and remove as necessary.
Do not use any type of cleaning fluid on this product.
8. Replace the heat exchanger by using the guide rails in the polystyrene and pushing up.
9. Replace the drain tray.
10. Replace the access panel and secure using the four screws.
11. Reconnect the condensate pipe to the condensate connector and ensure that there is the required amount of fall away from the unit.

Switch on the power to the unit and check that it is running correctly.

Should you have any queries relating to these instructions, please contact the Vectaire Technical Department on 01494 522333